

Examples of Applications Consuming Norwegian Linked Open Data

~ Regional Development and Environmentally Friendly Behavior ~

Dumitru Roman, SINTEF, Norway

Jens Kilde Mjelva and David Norheim, Computas AS, Norway

dumitru.roman@sintef.no, jens.kilde.mjelva@computas.com, david.norheim@computas.com

@ISO 15926 and Semantic Technologies 2012, 7th September 2012

Sogndal, Norway

Outline

- Open Data Movement
 - Linked Open Data

- Norwegian Linked Open Data – Use Cases
 - Monitoring Regional Development
 - Environmentally Friendly Behavior
- Requirements
- Architecture
- Data Sets
- Applications
- Summary

Open Data Movement

- Open Government - establish a modern cooperation among politicians, public administration, industry and private citizens by enabling more transparency, democracy, participation and collaboration
- The Open Government Partnership (launched on September 20, 2011)



- 8 founding governments
- 43 national governments commitments to OG

- Key enablers: free access to information and the possibility to freely use and re-use this information => Open Government Data (OGD)

Open Data Movement (cont')

- “Open Government Data” - worldwide movement to open up government/public administration data
 - Targeted to both human and machine-readable non-proprietary formats - for re-use
- “Open Data”
 - Data beyond just governmental institutions
 - Includes data from relevant stakeholder groups (e.g. citizens, industry, NGOs, science or education, etc.)
- Examples:
 - DIFI (<http://data.norge.no/>); UN (<http://data.worldbank.org>); Open Knowledge Foundation (<http://okfn.org>); New York Times (<http://data.nytimes.com>)

Open Government Data Principles

(<http://sunlightfoundation.com/policy/documents/ten-open-data-principles/>)

1. Data must be complete
2. Data must be primary
3. Data must be timely
4. Data must be accessible
5. Data must be machine-processable
6. Access must be non-discriminatory
7. Data formats must be non-proprietary
8. Data must be license-free
9. Data must be permanently available

From Open Data to Linked Open Data

- Crucial for data to be put into a context - new knowledge and more powerful services and applications
 - Interoperability and standards are key
- 5 Stars Model
 - ★ Information is available on the Web (any format) under an open license
 - ★★ Information is available as structured data (e.g. Excel instead of an image scan of a table)
 - ★★★ Non-proprietary formats are used (e.g. CSV instead of Excel)
 - ★★★★ URI identification is used so that people can point at individual data
 - ★★★★★ Data is linked to other data to provide context

What are the costs and benefits of ★ web data?

As a consumer ...	As a publisher ...
✓ You can see it.	✓ It is easy to publish.
✓ You can print it.	
✓ You can store it locally (on your hard drive or on an USB stick).	
✓ You can enter the data manually into another system.	

What are the costs and benefits of ★★ web data?

As a consumer, you can do everything that you could do with ★ web data, plus:	As a publisher ...
✓ You can directly process it with proprietary software to aggregate it, perform calculations, visualise it, etc.	✓ It is easy to publish.
✓ You can export it into another (structured) format.	

What are the costs and benefits of ★★★ web data?

As a consumer, you can do everything that you could do with ★★ web data, plus:	As a publisher ...
✓ You do not have to pay for a format over which a single entity has exclusive control	✓ It is easy to publish.

What are the costs and benefits of ★★★★ web data?

As a consumer, you can do everything that you could do with ★★★ web data, plus:	As a publisher ...
✓ You can link to it from any other place, either on the web or locally.	✓ You will need to invest some time slicing and dicing your data.
✓ You can bookmark it.	✓ You will need to assign URIs to data items and think about how to represent the data.
✓ You can re-use parts of the data.	✓ You have fine-granular control over the data items and can optimise their access (e.g. load balancing, caching, etc.)

What are the costs and benefits of ★★★★★ web data?

As a consumer, you can do everything that you could do with ★★★★ web data, plus:	As a publisher ...
✓ You can discover new data of interest while consuming other information.	✓ You will need to invest resources to link your data to other data on the web.
✓ You have access to the data schema.	✓ You make your data discoverable.
	✓ You increase the value of your data.

Linked Data Principles

1. Use URIs to identify things
2. Use HTTP URIs so that these things can be referred to and looked up ("dereferenced") by people and user agents
3. Provide useful information about the thing when its URI is dereferenced, using standard formats such as RDF/XML
4. Include links to other, related URIs in the exposed data to improve discovery of other related information on the Web

<http://www.w3.org/DesignIssues/LinkedData>

Outline

- Open Data Movement
 - Linked Open Data
- Norwegian Linked Open Data – Use Cases
 - Monitoring Regional Development
 - Environmentally Friendly Behavior
- Summary

The context (1):

PlanetData Large-scale Data Management

- FP7 Network of Excellence (2010-2014)
- Aim: establish an interdisciplinary, sustainable European community on large-scale data management
 - Publishing and managing new species of interlinked data sets
 - Improving the usefulness of existing data sources
 - Data sets, vocabularies, best practices for publishing self-descriptive data
 - Portal with data provisioning and management tools
 - Training infrastructure, learning resources, summer schools, standards
- PlanetData Programs:
 - Call 1: “Consuming Linked Data”



<http://planet-data.eu/>

PlanetData-NorthPole

Consuming and Improving Norwegian Linked Open Data for Regional Development and Environmental Friendly Behavior



The objectives of PlanetData-NorthPole are:

1. To **specify and implement two case studies** for demonstrating the use and benefits of LOD in *regional development* and *environmental friendly behaviour*, with a particular localization on Norway;
2. To **improve the existing Norwegian LOD and extend it** with new data sets to support the proposed case studies;
3. To **provide guidelines** for other countries in the use of LOD for regional development and environmental friendly behaviour applications.

- Participants:
 - Computas AS
 - SINTEF
- Duration: 6 months
- Budget: approx 120K Euro

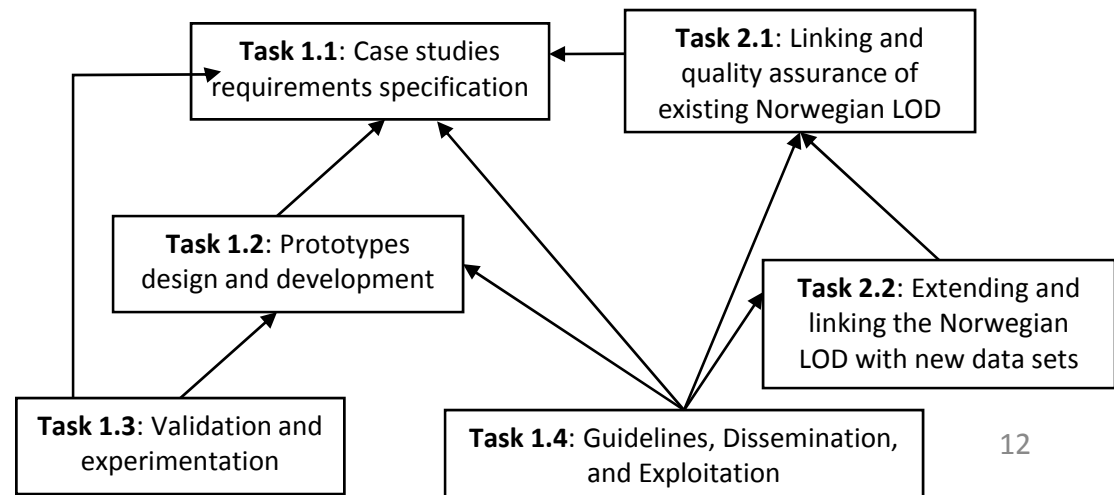

The context (2):

Semicolon II – Interoperability in Public Sector

- Aim: test and establish methods, tools and performance indicators to be used as the basis for recommendations and standards for enhancing collaboration across the public sector in Norway
- A multidisciplinary project
 - Policy development, Semantic interoperability, Interoperability platforms, Legislation, Cost/benefit analyses, Organisational interoperability
- <http://semicolon.no>

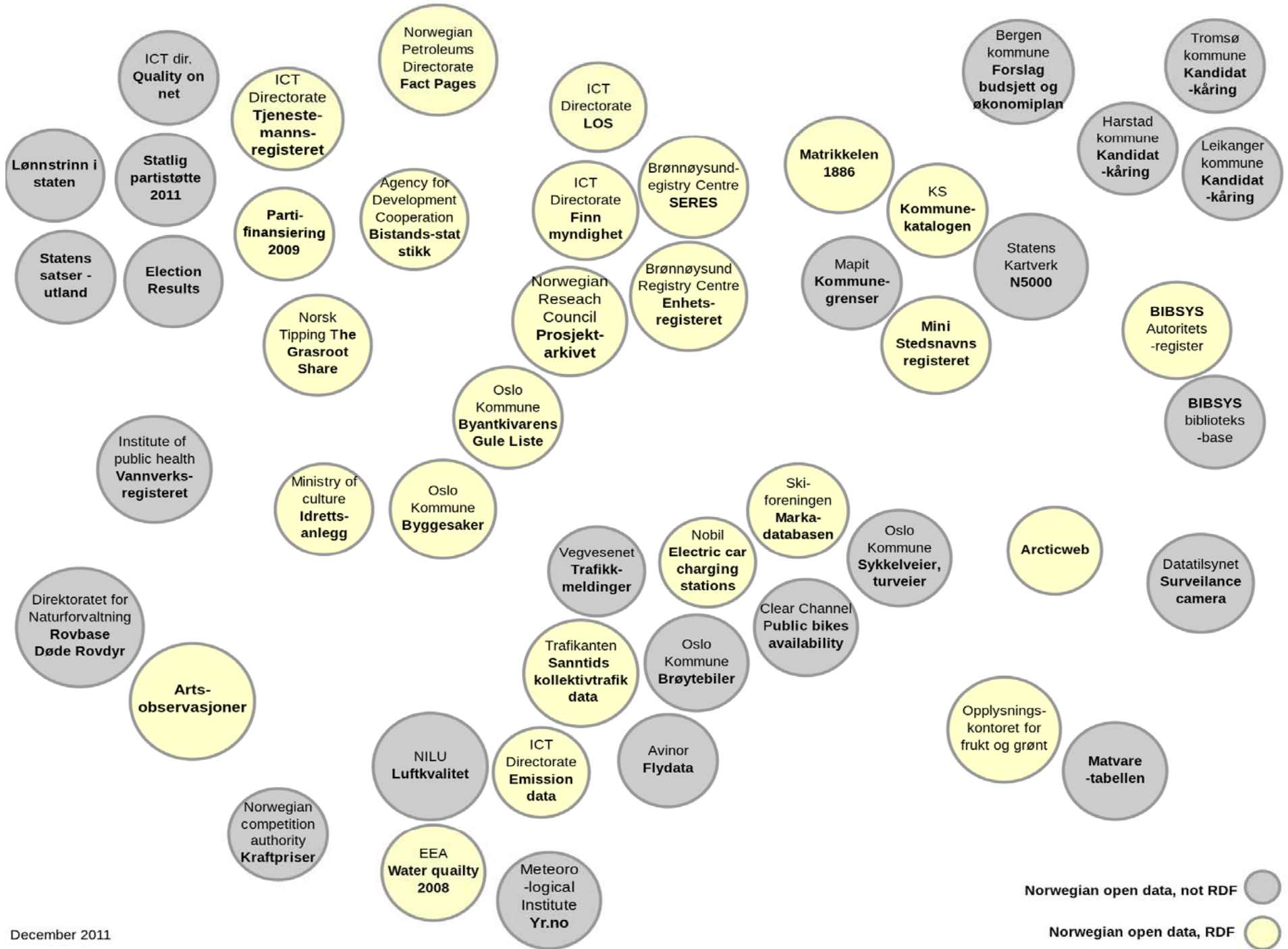

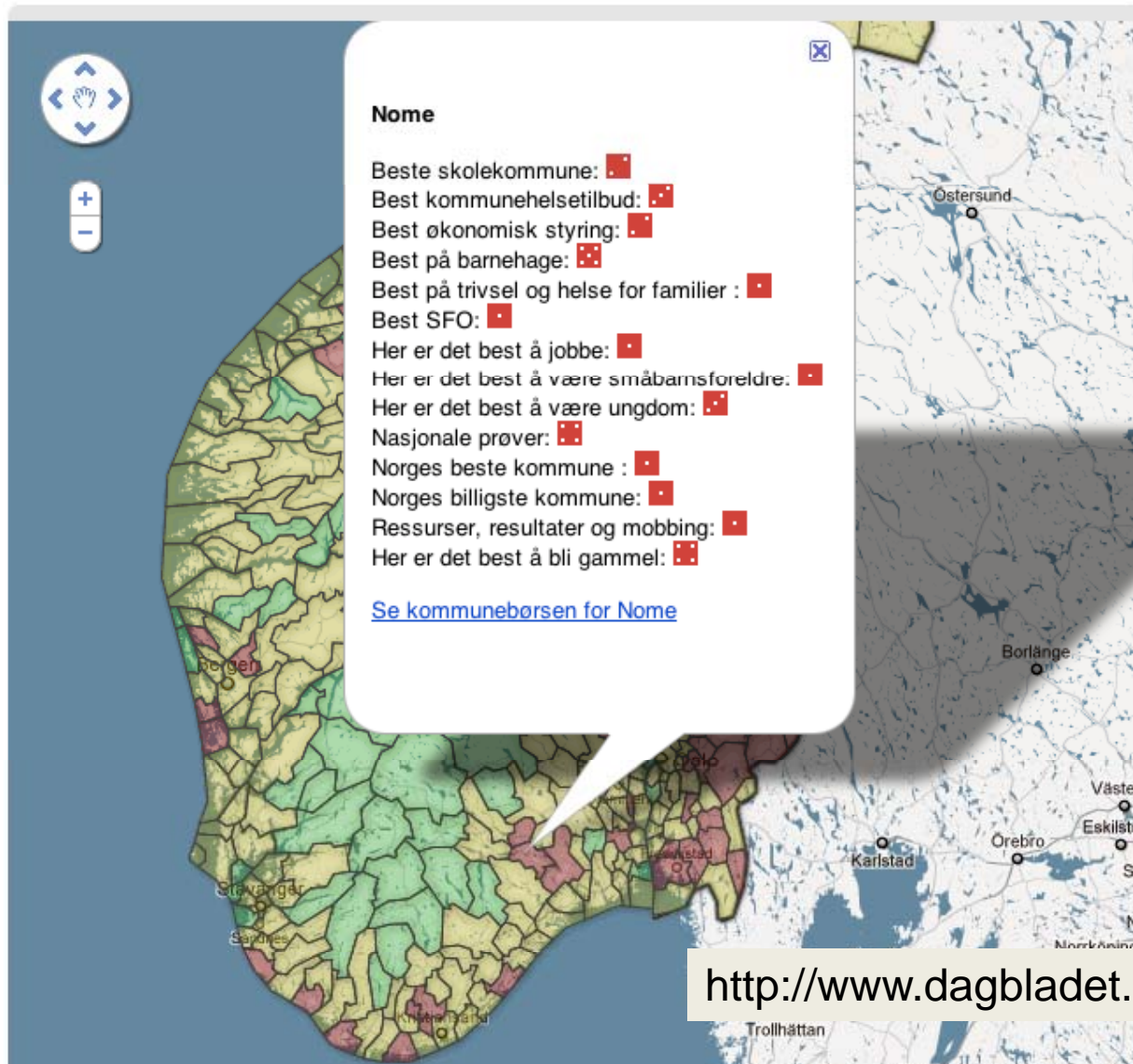

<http://www.dagbladet.no/kommuneborsen/>

Klikk på kartet for å sjekke din kommune.

Kategoriene: [Alle](#) [NORGES BESTE KOMMUNE](#) [Best økonomisk styring](#)
[Beste skolekommune](#) [Nasjonale prøver](#) [Ressurser, resultater og mobbing](#)
[Best kommunehelsetilbud](#) [Best å jobbe](#) [Best på barnehage](#) [Best SFO](#)
[Best å være småbarnsforeldre](#) [Best å være ungdom](#) [Norges billigste kommune](#)

Use Case 1 – Requirements

1. The system shall register data set selections
2. The system shall register data variable selections
3. The system shall register selections of parts of the visualized data
4. The system shall be connected to a chart visualization system
5. Various Linked Open Data shall be available to the system either through RESTful Web service request(s) or SPARQL-endpoints
6. The system should be able to add more LOD sets to visualize data from

Use Case 1 – Requirements (cont')

7. The system shall present the user with visualizations of the selected data sets
8. The system shall present the user with datasets and variables to choose to base the visualization on
9. The system shall visualize data connected to a geographical location on a geo chart
10. The application should be available through Web browsers without plugins
11. The application shall be user friendly

Use Case 1 – Application architecture outline

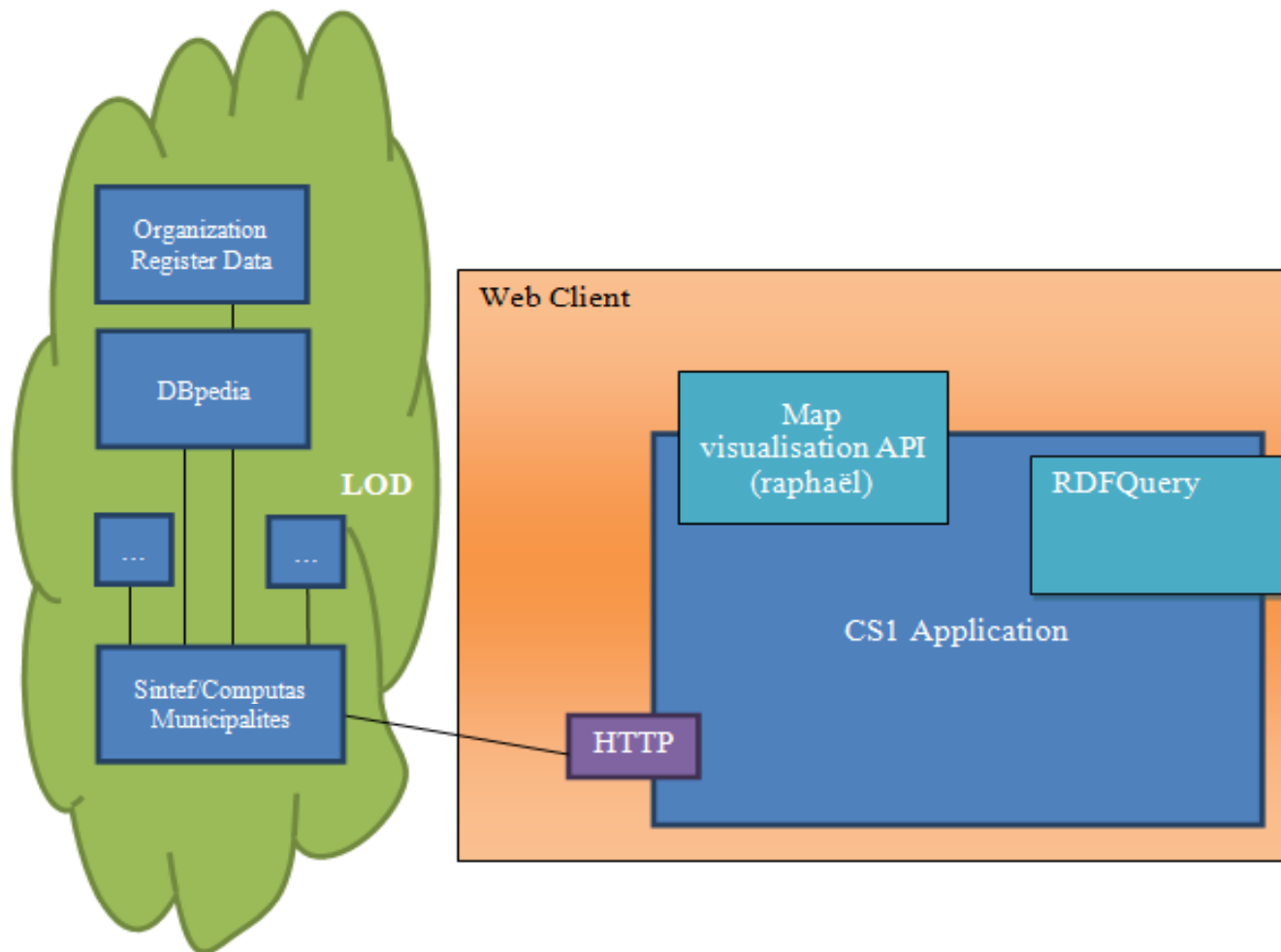

Use Case 1 – (Linked) (Open) Data Sources

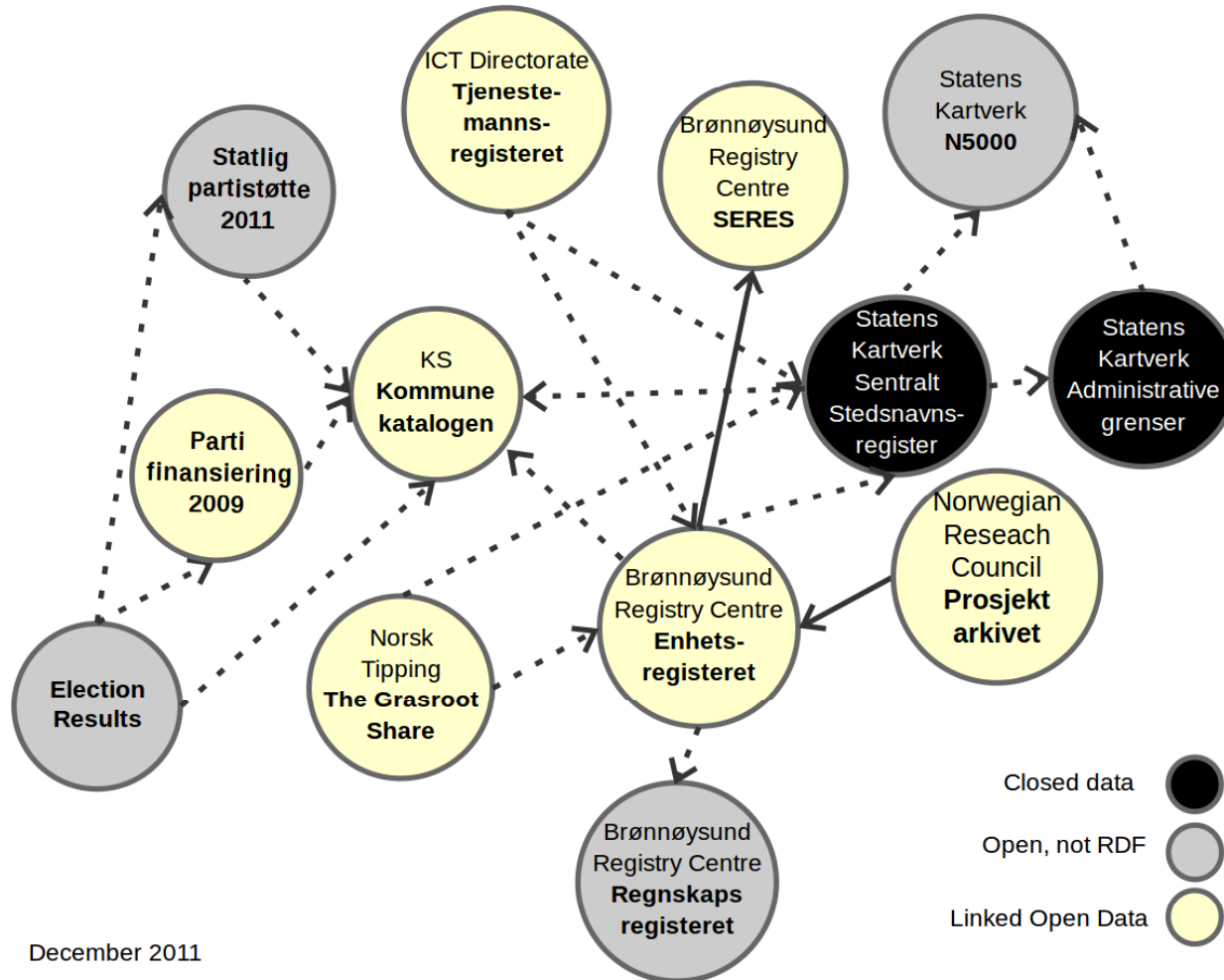

December 2011

Use Case 1 – LOD example

<http://opendata.computas.no/lod/id/enhet/986429360>

KARDE AS, en Enhet

Organisasjonsnr: 986429360

Organisasjonsform: Aksjeselskap (AS)

Nacekode:

70.220 - Bedriftsrådgivning og annen administrativ rådgivning

Antall ansatte: 8 (per 15.01.2011)

Adresse:

Skafjellveien 20
3070 SANDE I VESTFOLD
Norge

Kontaktperson:

Terje Johan Grimstad

• **andre roller:**

- Daglig leder/ adm.dirktør i [KARDE AS](#)
- Styremedlem i [KARDE AS](#)
- Kontaktperson i [TGR INVEST AS](#)
- Styrets leder i [TGR INVEST AS](#)
- Styremedlem i [TELLU AS](#)
- Styremedlem i [PALPACOM AS](#)

Styremedlemmer:

• Styrets leder

- Arthur Berg Reinertsen
 - **andre roller:**
 - Daglig leder/ adm.dirktør i [KARDE AS](#)
 - Styrets leder i [KARDE AS](#)
 - Kontaktperson i [ABR INVEST AS](#)
 - Styrets leder i [ABR INVEST AS](#)
 - Styrets leder i [TELLU AS](#)
 - Styrets leder i [PALPACOM AS](#)

```
<http://opendata.computas.no/lod/id/enhet/986429360>
  a
  <http://opendata.computas.no/dict/guid/Brønnøysundregistrene/Begrep/Enhet/4974> ;
  vocab:adresse
  [ a
  <http://opendata.computas.no/dict/guid/Brønnøysundregistrene/Begrep/Adresse/4967> , vcard:Address
  ;
  vocab:gateadresse "Skafjellveien 20" ;
  vocab:kommunenavn "SANDE" ;
  vocab:kommunenr "0713" ;
  vocab:land
  [ a
  geoinfo:self_governing ,
  <http://opendata.computas.no/dict/guid/Brønnøysundregistrene/Begrep/Land/4908> ;
  rdfs:seeAlso <http://www.geonames.org/countries/NOR/> ;
  vocab:landNavn "Norge" ;
  vocab:landkode "NOR" ;
  geoinfo:codeISO3 "NOR"
  ] ;
  vocab:postnr "3070" ;
  vocab:poststed "SANDE I VESTFOLD" ;
  hvor:kommunenr "0713" ;
  hvor:postnr "3070" ;
  hvor:poststed "SANDE I VESTFOLD" ;
  vcard:street-address
  "Skafjellveien 20"
  ] ;
  vocab:ansvarskapital
  [ a
  vocab:Ansvarskapital ;
  vocab:kapitalbeløp "100000.0"^^<http://www.w3.org/2001/XMLSchema#double> ;
  vocab:kapitaltype "Aksjekapital"@no ;
  vocab:kapitalvaluta "NOK"
  ] ;
  vocab:antAnsattePåDato
  [ a
  vocab:AntAnsattePåDato ;
  vocab:antAnsatte "8"^^<http://www.w3.org/2001/XMLSchema#long> ;
  vocab:gyldigFraDato "2011-01-
  14T23:00:00Z"^^<http://www.w3.org/2001/XMLSchema#dateTime>
  ] ;
  vocab:enhetsnavn "KARDE AS" ;
  vocab:erEnhetIRolle _:b22 , _:b1 , _:b13 , _:b14 , _:b24 , _:b32 , _:b23 , _:b28 , _:b6 ,
  _:b33 , _:b8 , _:b30 ;
  vocab:nacekode
  [ a
  nace:Activity ,
  <http://opendata.computas.no/dict/guid/Brønnøysundregistrene/Begrep/Næringskode/4960> ;
  rdfs:seeAlso "http://www4.ssb.no/stabas/ItemsFrames.asp?ID=5552001&Language=nb" ;
  nace:broader <http://ec.europa.eu/eurostat/ramon/rdfdata/nace_r2/70.22> ;
  nace:code "70.220" ;
  nace:name "Bedriftsrådgivning og annen administrativ rådgivning"@no ;
  vocab:nacekodekode "70.220" ;
  vocab:nacekodedetekst "Bedriftsrådgivning og annen administrativ rådgivning"@no
  ] ;
  ] ;
```

Select properties for visualization

- Total population of each Norwegian municipality (DBPedia)
- Population density per km2. for Norwegian municipalities (DBPedia)
- Population increase (%) in each Norwegian municipality? (DBPedia)
- Total number of organizations (Enhetsregisteret)
- Number of computer programming and consultancy organizations (Enhetsregisteret)
- Number of accomodation organizations (Enhetsregisteret)
- Number of 'construction of residential and non-residential buildings'-organizations (Enhetsregisteret)
- Number of fitness facility organizations (Enhetsregisteret)
- Total number of state employees (Tjenestemannsregisteret)
- Total number of male state employees (Tjenestemannsregisteret)
- Total number of female state employees (Tjenestemannsregisteret)
- Number of male state employees, age 20 (Tjenestemannsregisteret)
- Number of female state employees, age 20 (Tjenestemannsregisteret)
- Number of male state employees, age 40 (Tjenestemannsregisteret)
- Number of female state employees, age 40 (Tjenestemannsregisteret)
- Total gaming subsidies given to organizations (Grasrotandelen 2009)
- Gaming subsidies given to sports organizations (Grasrotandelen 2009)
- Gaming subsidies given to religious organizations (Grasrotandelen 2009)
- Gaming subsidies given to art- and culture organizations (Grasrotandelen 2009)
- Gaming subsidies given to political organizations (Grasrotandelen 2009)



Select properties for visualization

- Total population of each Norwegian municipality (DBPedia)
- Population density per km2. for Norwegian municipalities (DBPedia)
- Population increase (%) in each Norwegian municipality? (DBPedia)
- Total number of organizations (Enhetsregisteret)
- Number of computer programming and consultancy organizations (Enhetsregisteret)
- Number of accomodation organizations (Enhetsregisteret)
- Number of 'construction of residential and non-residential buildings'-organizations (Enhetsregisteret)
- Number of fitness facility organizations (Enhetsregisteret)
- Total number of state employees (Tjenestemannsregisteret)
- Total number of male state employees (Tjenestemannsregisteret)
- Total number of female state employees (Tjenestemannsregisteret)
- Number of male state employees, age 20 (Tjenestemannsregisteret)
- Number of female state employees, age 20 (Tjenestemannsregisteret)
- Number of male state employees, age 40 (Tjenestemannsregisteret)
- Number of female state employees, age 40 (Tjenestemannsregisteret)
- Total gaming subsidies given to organizations (Grasrotandelen 2009)
- Gaming subsidies given to sports organizations (Grasrotandelen 2009)
- Gaming subsidies given to religious organizations (Grasrotandelen 2009)
- Gaming subsidies given to art- and culture organizations (Grasrotandelen 2009)
- Gaming subsidies given to political organizations (Grasrotandelen 2009)

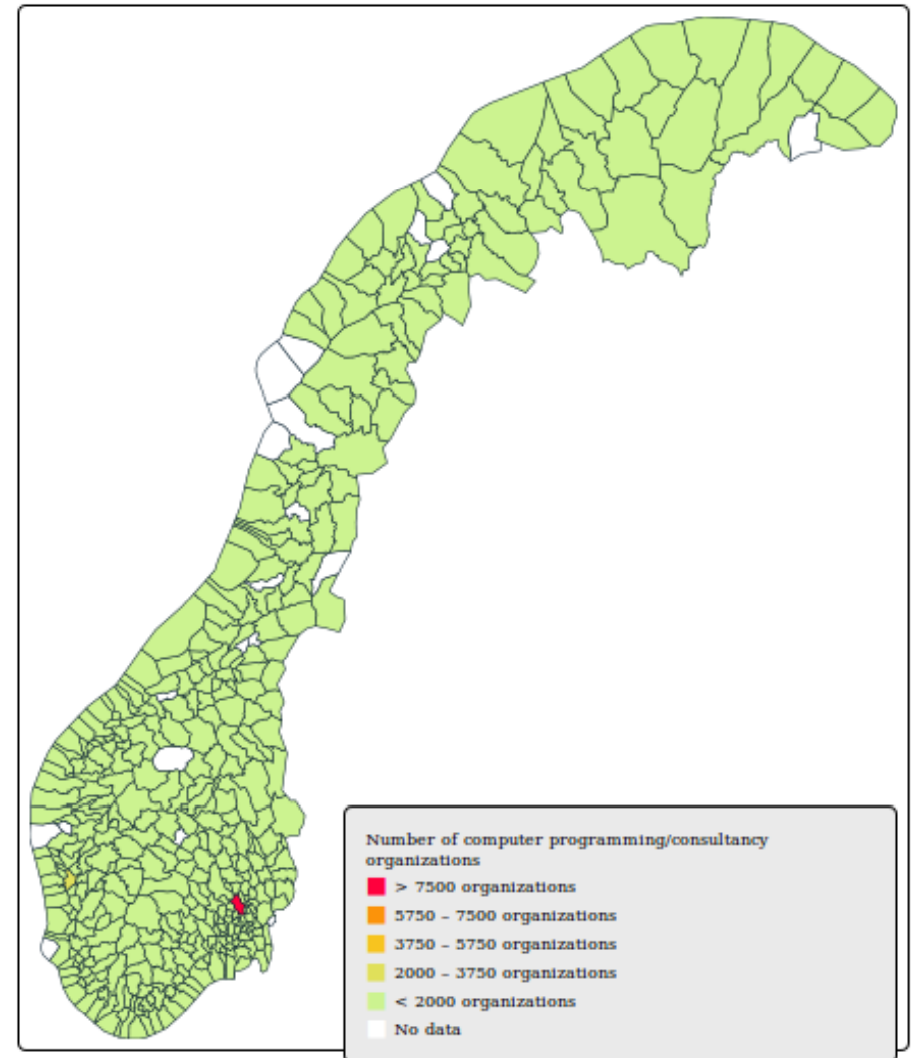

Select properties for visualization

- Total population of each Norwegian municipality (DBPedia)
- Population density per km2, for Norwegian municipalities (DBPedia)
- Population increase (%) in each Norwegian municipality? (DBPedia)
- Total number of organizations (Esbetregisteret)
- Number of computer programming and consultancy organizations (Esbetregisteret)
- Number of accomodation organizations (Esbetregisteret)
- Number of construction of residential and non-residential buildings-organizations (Esbetregisteret)
- Number of fitness facility organizations (Esbetregisteret)
- Total number of state employees (Tjenestemannsregisteret)
- Total number of male state employees (Tjenestemannsregisteret)
- Total number of female state employees (Tjenestemannsregisteret)
- Number of male state employees, age 20 (Tjenestemannsregisteret)
- Number of female state employees, age 20 (Tjenestemannsregisteret)
- Number of male state employees, age 40 (Tjenestemannsregisteret)
- Number of female state employees, age 40 (Tjenestemannsregisteret)
- Total gaming subsidies given to organizations (Gruasetandelen 2009)
- Gaming subsidies given to sports organizations (Gruasetandelen 2009)
- Gaming subsidies given to religious organizations (Gruasetandelen 2009)
- Gaming subsidies given to art- and culture organizations (Gruasetandelen 2009)
- Gaming subsidies given to political organizations (Gruasetandelen 2009)

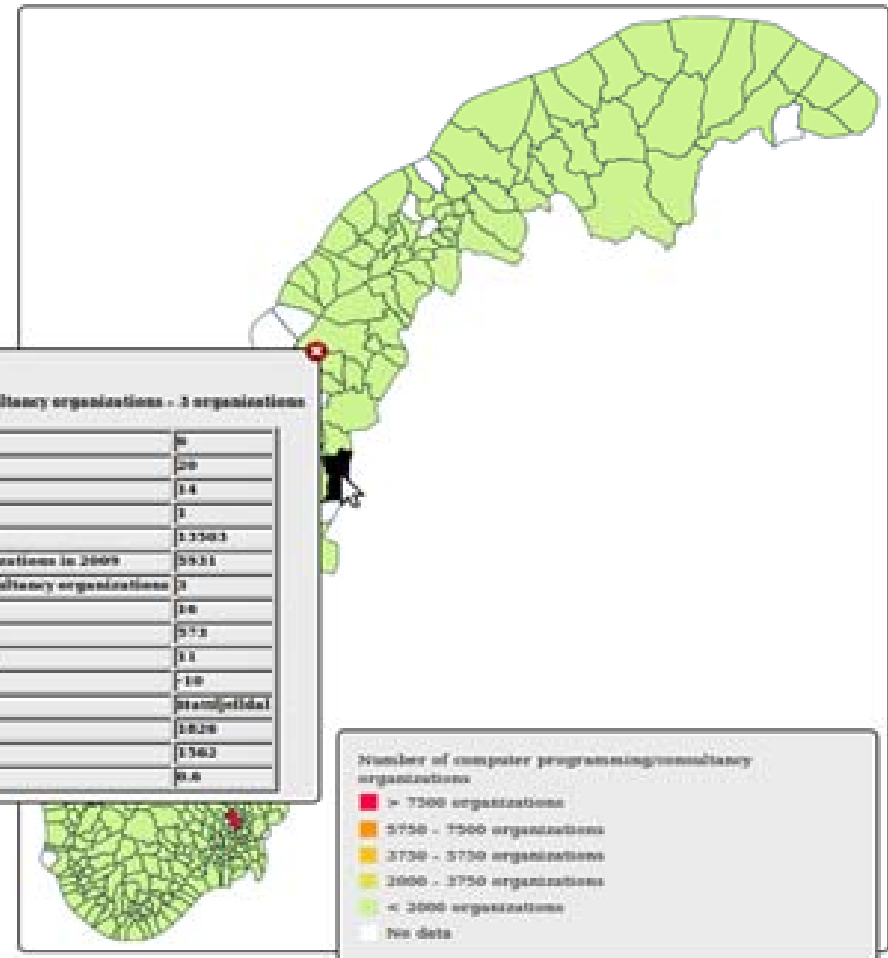

Stamtjøfidal

Number of computer programming/consultancy organizations - 3 organizations

Male state employees	0
Female state employees	20
Female state employees	14
Female state employees, age 40	1
Total gaming subsidies in 2009	13503
Gaming subsidies given to sports organizations in 2009	5931
Number of computer programming/consultancy organizations	3
Number of construction organizations	10
Number of organizations	373
Number of accomodation organizations	11
Population increase	-10
Municipality name	Stamtjøfidal
Municipality nr	1020
Total population	1362
Population density	0.0

Number of computer programming/consultancy organizations

- > 7500 organizations
- 5750 - 7500 organizations
- 3750 - 5750 organizations
- 2000 - 3750 organizations
- No data

Select properties for visualization

- Total population of each Norwegian municipality (DBPedia)
- Population density per km2. for Norwegian municipalities (DBPedia)
- Population increase (%) in each Norwegian municipality? (DBPedia)
- Total number of organizations (Enhetsregisteret)
- Number of computer programming and consultancy organizations (Enhetsregisteret)
- Number of accomodation organizations (Enhetsregisteret)
- Number of 'construction of residential and non-residential buildings'-organizations (Enhetsregisteret)
- Number of fitness facility organizations (Enhetsregisteret)
- Total number of state employees (Tjenestemannsregisteret)
- Total number of male state employees (Tjenestemannsregisteret)
- Total number of female state employees (Tjenestemannsregisteret)
- Number of male state employees, age 20 (Tjenestemannsregisteret)
- Number of female state employees, age 20 (Tjenestemannsregisteret)
- Number of male state employees, age 40 (Tjenestemannsregisteret)
- Number of female state employees, age 40 (Tjenestemannsregisteret)
- Total gaming subsidies given to organizations (Grasrotandelen 2009)
- Gaming subsidies given to sports organizations (Grasrotandelen 2009)
- Gaming subsidies given to religious organizations (Grasrotandelen 2009)
- Gaming subsidies given to art- and culture organizations (Grasrotandelen 2009)
- Gaming subsidies given to political organizations (Grasrotandelen 2009)

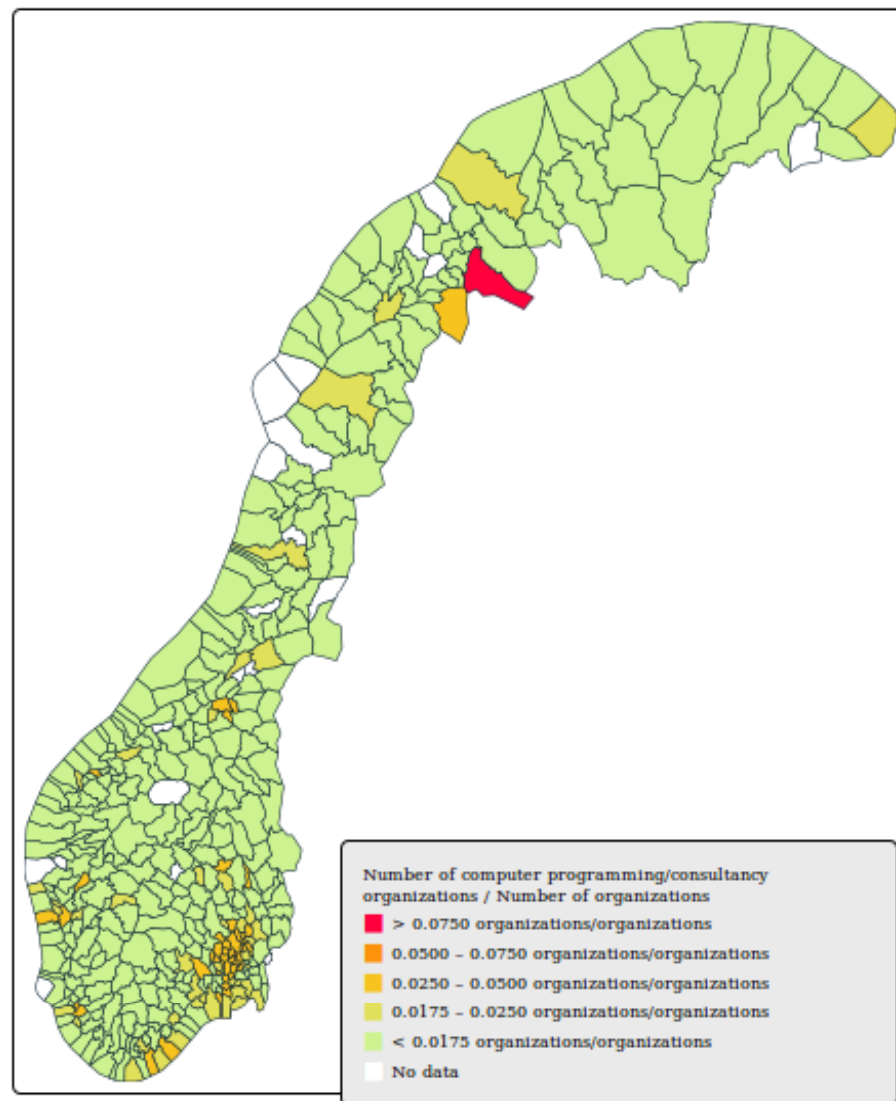

Environmental friendly behaviour (Use Case 2)

- **Problem statement:** Faced with different transportation options for a short trip, which are the most environmental-friendly options given constraints like time, weather, traffic and private preferences.

- Typically different options
 - Public transportation (bus/tram/metro/train)
 - Private car (electric/gas/diesel) car, taxi
 - Cycling, walking

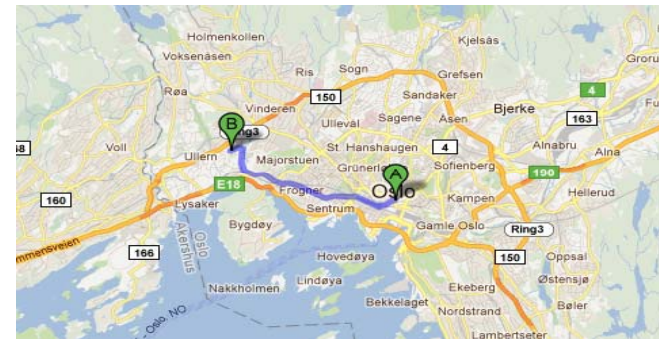

- Constraints: Time, avoid bad weather, polluted zones, traffic, private preferences
- Environmental parameters: CO2 emissions, energy efficiency
- **Added value proposition:** Enable smarter/faster environmental friendly decision making for local trips when options are available
 - Assist the user's decision making wrt travelling from his current position to the position of the next event in the user's calendar

Use Case 2 – Requirements

1. The user shall not have to enter any information when starting the app
2. Various Linked Open Data shall be available to the system either through RESTful Web service request(s) or SPARQL-endpoints
3. Private user data – calendar events and the geographic position of the user – shall be made available to the app
4. Communication, forming requests - The system shall generate requests to the required LOD systems
5. An initial request will be formed with arguments fetched from the closed (user) data from req. #3, e.g.: “Find the 15 closest public transportation stops to the user’s position”

Use Case 2 – Requirements (cont')

6. Communication, handling replies - The system shall parse the data it receives and add emission information to a transport alternative by combining emission data with the transport data
7. The system shall add entries (events) to the user's calendar corresponding to the transportation alternatives found. The added calendar event(s), i.e. travel alternatives shall at least contain the following information: Start time, end time, transport type, route description and environmental friendliness (e.g. CO2 emission)
8. Application result quality - The added calendar entries should to be of quality wrt taking the user from his current position to the actual address of the calendar event the entries where based on.
9. The app could display a notification telling whether transportation alternatives where found or not
10. The data lifting and application shall try to utilise common linked data vocabularies for transportation and environment

Use Case 2 – Application structure outline

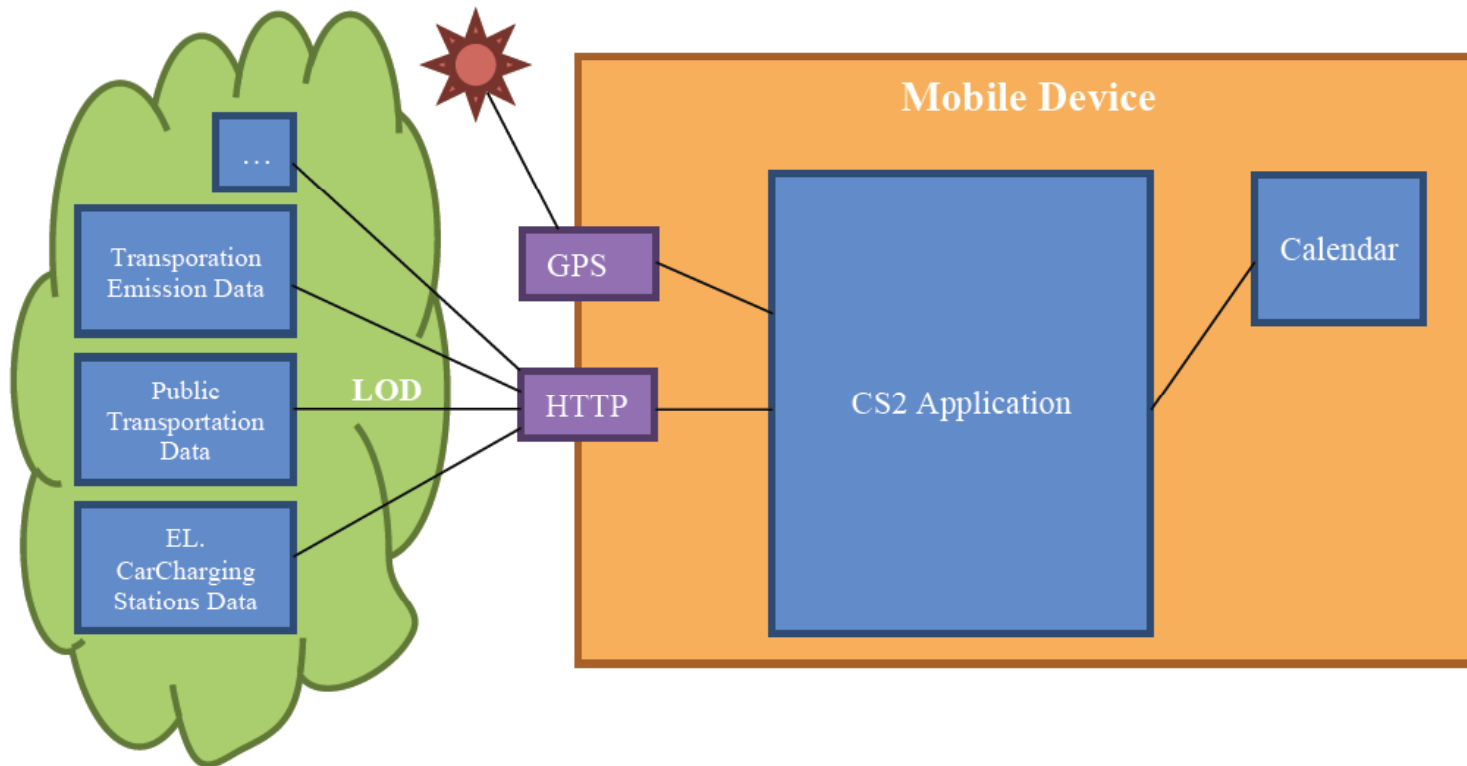

Use Case 2 – (Linked) (Open) Data Sources

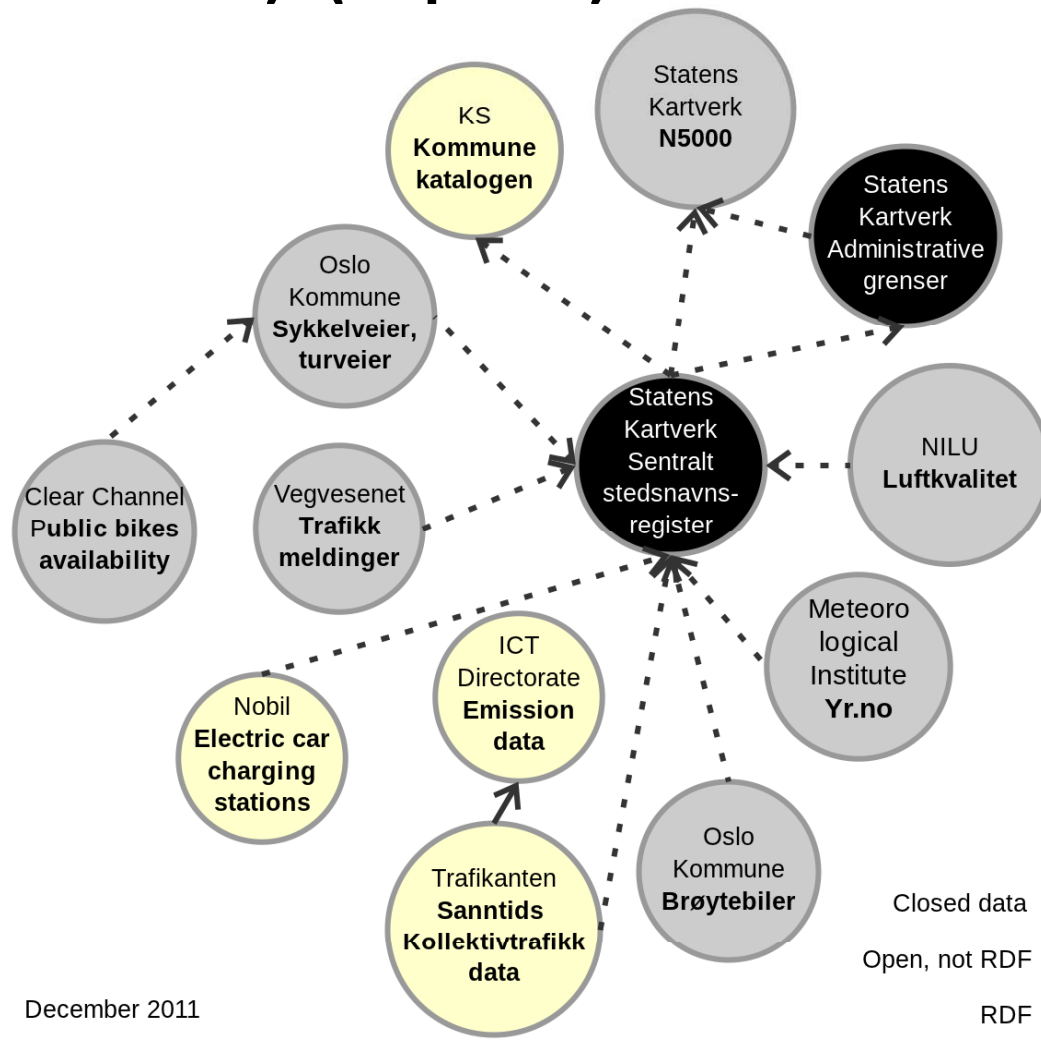

December 2011

Use Case 2 – LOD example

<http://opendata.computas.no/nobil/id/chargingStation/1121>

Universitetet i Agder, Kristiansand

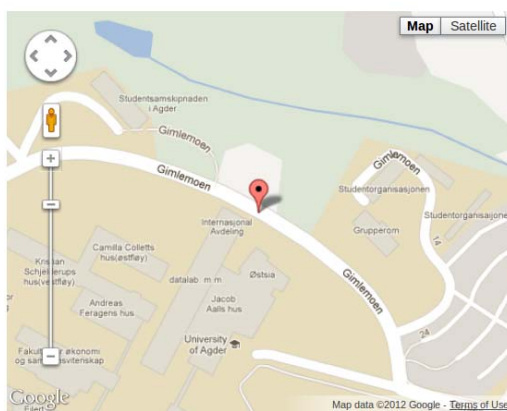

Picture:	http://www.nobil.no/img/ladestasjonbilder/1121.jpg
Thumbnail:	http://www.nobil.no/img/ladestasjonbilder/tn_1121.jpg
Owner:	Universitetet i Agder
Available slots:	2
Place type:	Gateplan
Charging station ID:	1121
Availability:	Besøkende
Contact info:	drift-krs@uia.no
Place description:	Til høyre for hovedbygning. Ingen ordentlige parkeringsplasser, men et skilt og to stikkontakter i en vegg.
Time limit (hours):	0
Street address:	Gimlemoen 25
Postal code:	4604
Municipal number:	1001
Postal area:	KRISTIANSAND S
Latitude:	58.1644
Longitude:	8.0038
Geometry:	POINT(58.1644 8.0038)
Point:	8.0038 58.1644
Charging speed:	16A
Access key:	Åpen
Charging outlets:	2

UC2 – Demo Screenshots

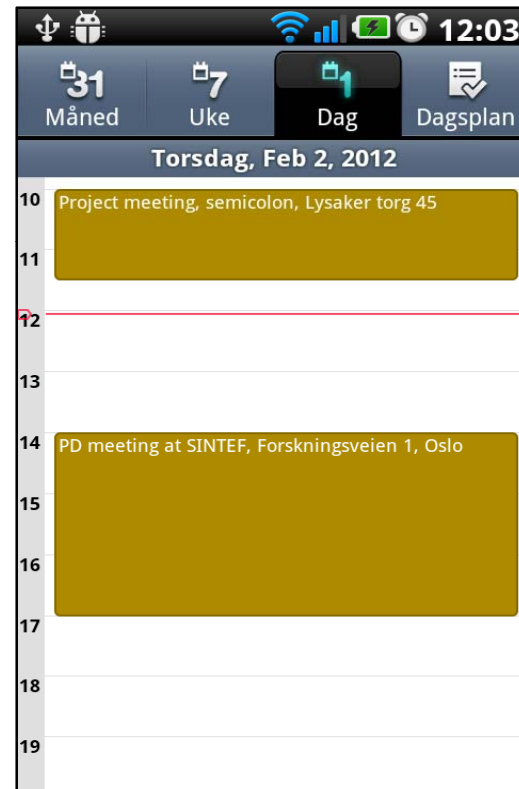
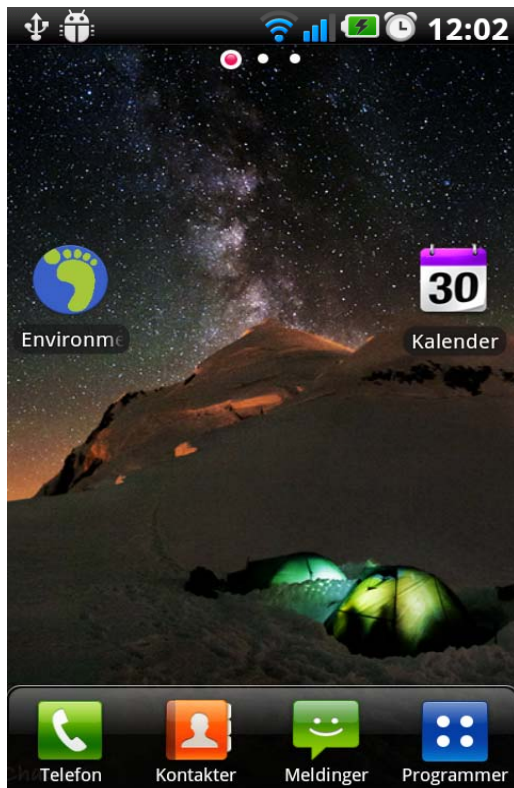

UC2 – Demo Screenshots

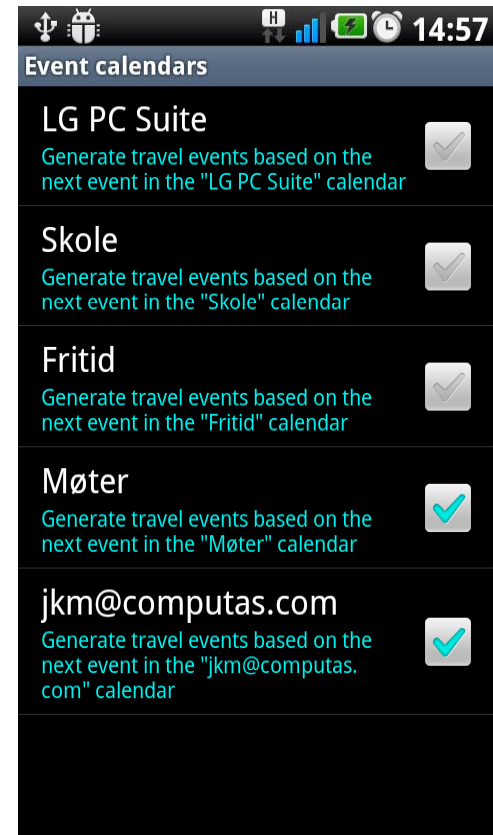
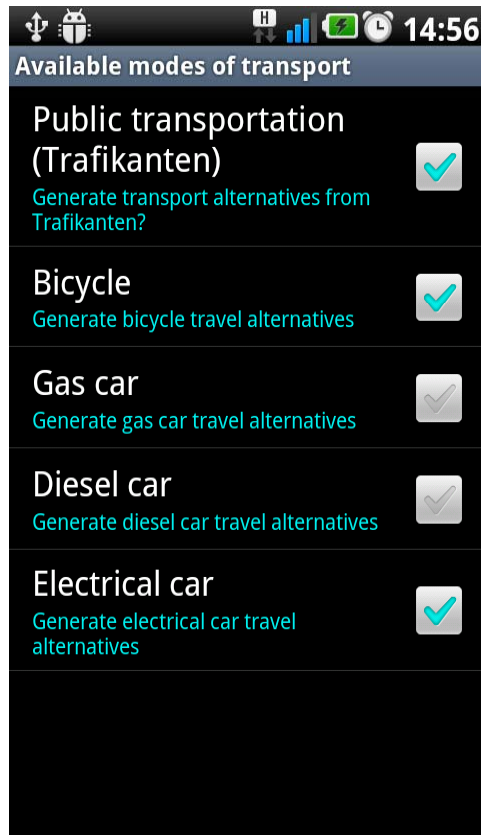
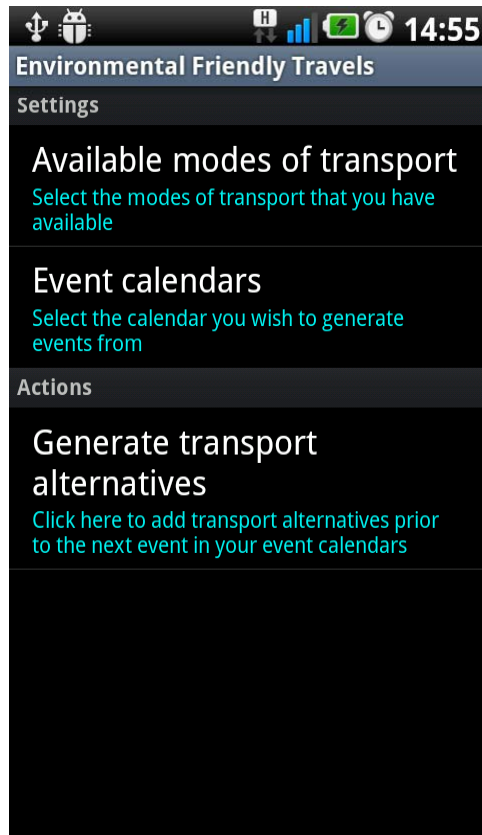

UC2 – Demo Screenshots



UC2 – Demo Screenshots

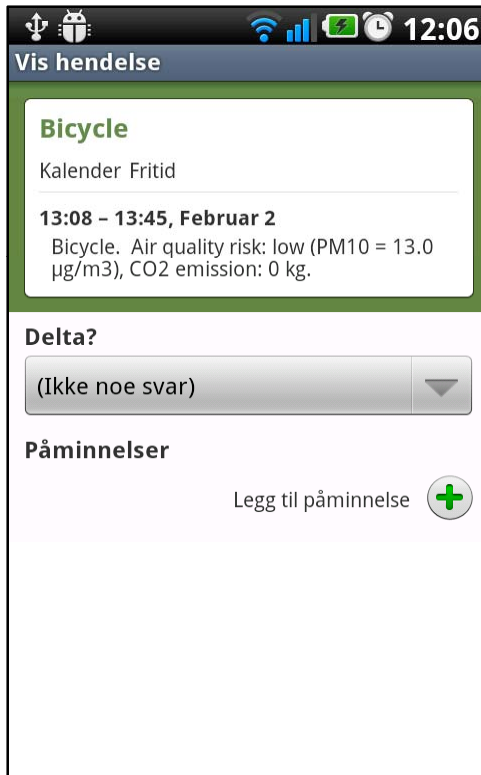

Outline

- Open Data Movement
 - Linked Open Data
 - Norwegian Linked Open Data – Use Cases
 - Monitoring Regional Development
 - Environmentally Friendly Behavior
- Summary

UC1 – Further improvements

- Plug-in more data sets to the application
 - More questions could be answered
- Improve the graphical experience
- Validation with data journalists (e.g. through workshop/questionnaires)
 - MediArena
<http://www.mediarena.no/>
“The MediArena Business Cluster is a unique collaboration project between global technology corporations, national broadcasters and small, forward-leaning meditech entrepreneurs - all situated in Bergen, Norway.”
 - Dagbladet Kommunebørsen
<http://www.dagbladet.no/kommuneborsen/>

UC2 – Further improvements

- Integrate the app with data from the Veimeldinger data set
- Validation

Summary

- Open Data Movement
 - More transparency, participation and collaboration
 - Free access to information and the possibility to freely use and re-use this information
- Linked Open Data
 - Interoperability, standards, tools for Open Data
- Two use cases for the Norwegian Linked Open Data
 - Monitoring Regional Development
 - Environmentally Friendly Behavior

Reports

- Case studies: definition, requirements, design
 - <http://planet-data-wiki.sti2.at/uploads/e/ed/D12.1.1.pdf>
- Report on prototypes, development, validation and evaluation
 - <http://planet-data-wiki.sti2.at/uploads/6/6d/D12.1.2.pdf>
- Report on quality improvements of existing Norwegian LOD
 - <http://planet-data-wiki.sti2.at/uploads/8/81/D12.2.1.pdf>
- Report on Norwegian LOD extensions
 - <http://planet-data-wiki.sti2.at/uploads/6/6a/D12.2.2.pdf>

Thank you!

Questions?

<i>Title</i>	<i>Author</i>	<i>URL to data set homepage</i>	<i>Triples</i>	Star scheme score (Lee, 2006)	Case study applicability	Comments
Enhetsregisteret	Brønnøysund Registry Centre	Computas http://opendata.computas.no/about/#BR-Enhetsregisteret	> 4.500.000	5	Case study #1	RESTful RDF WS Wrapper
Kommunekatalogen	KS	Univ. of Oslo http://sws.ifi.uio.no/sparqler/	Ca. 2.000	3	Case study #1 Case study #2	SPARQL
NFR prosjektarkiv	Norwegian Research Council	Computas http://opendata.computas.no/about/#NFR-Prosjektkatalog	Ca. 200.000	5	Case study #1	SPARQL
Partifinansiering2009	The Ministry of Government Administration, Reform and Church Affairs	Univ. of Oslo http://heim.ifi.uio.no/audus/rdf/partifinansiering.rdf	Ca. 100.000	4	Case study #1	RDF file dump
Grasrotandelen	NorskTipping	Computas http://opendata.computas.no/joseki/	Ca. 70.000	4	Case study #1	SPARQL
Trafikkantensanntid	Oslo Kommune	Computas http://opendata.computas.no/trafikanten/id/stop/3010030	Ca. 50.000	3	Case study #2	RESTful RDF WS Wrapper
Electric car charging stations	Nobil	Computas http://opendata.computas.no/nobil/id/chargingStation/902	Ca. 1.100	3	Case study #2	RESTful WS Wrapper (RDF returning)
Idrettsanlegg	Ministry of Culture	Computas http://opendata.computas.no/joseki/	Ca. 1.000.000	3	Case study #2	SPARQL
Emission data	Norwegian ICT Directorate	Computas http://opendata.computas.no/resource/emission/EI-bil	Ca. 150	4	Case study #2	SPARQL + RESTful WS (RDF returning)
Tjenestemannsregisteret	Norwegian ICT Directorate	Computas http://opendata.computas.no/about/#Difi-Tjenestemannsregisteret	Ca. 1.000.000	5	Case study #1	SPARQL + RESTful WS (RDF returning)
SERES	Brønnøysund Registry Centre	Computas http://opendata.computas.no/about/#BR-Seres	Ca. 50.000	5	Case study #1	RESTful WS Wrapper (RDF returning)